

Omega Sky Xi LGW

184÷684 kW



General

Water-condensed liquid chillers and heat pumps for indoor applications; screw compressor with variable compression ratio and inverter for capacity modulation.

Configurations

HPW: reversible heat pump version on water side

OH: non-reversible heat pump version

/LN: silenced unit

/DC: execution featuring a desuperheater

Strengths

- ▶ Maximum efficiency at partial loads: SEER up to 8,2 and SEPR up to 9
- ▶ Ecodesign Tier 2 compliant
- ▶ Refrigerant R1234ze with GWP<1
- ▶ Hybrid Falling Film evaporator with low refrigerant load
- ▶ Variable Vi screw compressor with external inverter
- ▶ Version with chiller and heat pump, each with optimised operating range
- ▶ Hot water production up to 65 ° C
- ▶ BlueThink advanced control with integrated web server. Multilogic function and Blueye® supervision system. (options)



Omega Sky Xi LGW

Description of accessories

Refrigerant circuit accessories	8
Hydraulic circuit accessories	10
Electrical accessories	13
Other accessories	19

Technical specifications

21

Ecodesign

24

RANGE OMEGA SKY Xi LGW

Electrical specifications

29

Flow rate ranges of heat exchangers

31

Operating limits

32

Omega Sky Xi LGW - Omega Sky Xi LGW OH - Omega Sky Xi LGW HPW	32
---	----

Noise levels

33

Dimensional diagrams

34

Installation advice

35

Water characteristics	35
Glycol mixtures	35
Minimum water content in the system	36
Installation site	37



THE FUTURE OF REFRIGERANTS THAT REDUCE GREENHOUSE EFFECT

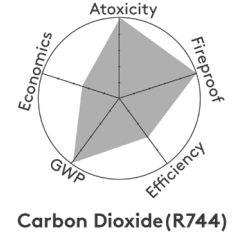
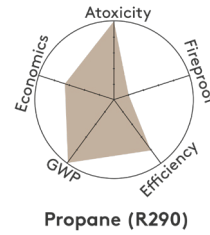
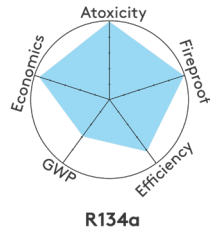
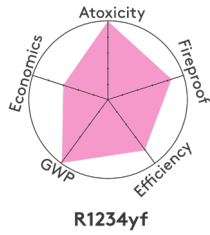
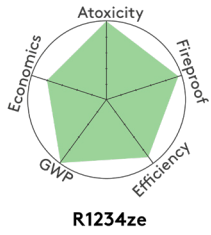

To reduce the emission into the atmosphere of gases that contribute to increasing the greenhouse effect, the European Union has set itself the target of reducing the use of F-gases by two-thirds of the 2014 level by 2030. Although these fluids have allowed a drastic reduction in the use of high ODP (Ozone Depletion Potential) refrigerants, their high GWP value and their longevity in the atmosphere (if released, they remain there for hundreds of years) contribute to the increase in global warming up to 8,000 times more than carbon dioxide.

The application of these regulations will lead to a progressive reduction in the use of refrigerants such as R134a and R410A and therefore substitute refrigerant fluids will gradually take hold.

There already exist various alternatives to F-Gases but, for each of them, the safety, investment and sustainability implications need to be carefully considered.

F-gases such as R410A or R134a have the indisputable advantage of being non-toxic and absolutely non-flammable. Paradoxically, the chemical properties that make these refrigerants safe are the same ones that cause such a prolonged resistance of the molecule in the atmosphere and therefore a high GWP.

If, in searching for an alternative, we look at natural refrigerants, such as carbon dioxide (R744), ammonia (R717) or hydrocarbons such as propane (R290), we actually have very low or zero GWP, but their toxicity and/or extreme flammability will have to be accepted. This will turn into higher costs of the machine and of the system in order to guarantee their safety.

In fact, the technological costs arising from the use of the various refrigerants must also be considered:

- units that use carbon dioxide as refrigerant need to work with such high pressure values (even higher than 100bar) that they are potentially explosive. This involves extremely onerous construction choices that justify their use only in the refrigeration field
- units that use ammonia must obligatorily be made completely of steel and use specific compressors and components. To this are added the setting up costs that, in view of the extreme toxicity of the fluid, will have to prevent contamination and poisoning hazards. All this limits the use of this fluid to only extremely high capacity systems, normally above a MW
- for units that use propane, all the necessary counter-measures must be taken to prevent the risk of explosion due to its very high flammability, and this turns into the obligation to use ATEX components, which are extremely costly

WHY R1234ZE

LGW stands for Low Global Warming Potential and identifies the units using the HFO refrigerant R1234ze.

LGW aims at offering an environmentally and economically sustainable alternative to conventional models based on R134a refrigerant.

R1234ze is a pure compound (Hydro-Fluoro-Olefin) featuring GWP<1 (*), equivalent to natural fluids.

R1234ze is rated as non dangerous (PED group 2 fluid).

It is also classified as A2L according to ASHRAE standard 34:

- Non toxic.
- Lower flammability fluid (or mildly flammable).

Thus LGW units represent the best future-proof choice, especially in Countries that:

- Impose legislation restrictions or bans on units with high GWP refrigerants.
- Offer incentive schemes for systems with low environmental impact.
- Impose specific taxation on high GWP refrigerants - or are likely to do it in the future.

Moreover, its minimum GWP value is decisive for projects:

- Addressed to obtain building certification credits linked to the adoption of best available environmental solutions.
- Adopting voluntary targets to minimize the system's environmental footprint.

All this is also beneficial to unit's commissioning, operation and maintenance – leading to overall cost effectiveness.

Specific measures are implemented on LGW models, to ease their adoption into the most stringent projects and enhance the overall safety features.

Omega Sky Xi LGW

Omega Sky Xi is a water-condensed liquid chiller for indoor applications, available in heat pump version also.

This range features a semi-hermetic, inverter-controlled screw compressor to obtain maximum performances at partial loads, a latest generation Hybrid Falling Film evaporator with low refrigerant load, and a shell and tube condenser.

These elements make Omega Sky Xi an extremely performing machine in all operating conditions, which enables it to largely exceed the targets mandated by the existing regulations and to ensure maximum comfort levels.

REFRIGERANT

Refrigerant R1234ze (GWP<1*)

(*) GWP (AR5), pursuant to IPCC V, evaluated over a span of 100 years.

STRUCTURE

Consists of polyester powder coated hot dip galvanised sheet steel profiles (RAL 9005).

The electrical control panel is made in a polyester powder-coated hot dip galvanised sheet steel box (RAL 7035).

COMPRESSORS

Units fit innovative screw compressors with a variable compression ratio, which ensure optimised operation under all operating conditions.

The BlueThink controller constantly monitors the evaporating and condensing temperatures of the unit and changes the compression ratio of the compressors to obtain the maximum achievable efficiency.

The compressors in use are designed according to an exclusive BlueBox specification in order to achieve maximum efficiency both under partial and full load conditions. Continuous reduction of the output capacity is implemented with a regulation from 25% to 100% in order to achieve the highest energy efficiency levels on the market, with special reference to cooling applications. The variation of the compression ratio caused by the sliding of the internal slide valve, in combination with capacity reduction of the refrigeration demand by the inverter, allows for the maximisation of the energy efficiency of the unit in all operating conditions.

In addition to managing capacity modulation, BlueThink also controls all safety devices so that the compressor can operate within its operating limits at all times and simultaneously safeguard its operation and reliability. Compressor lubrication is ensured by the pressure difference between the delivery and the suction lines, thanks to the regulation action performed by BlueThink.

All the compressors are fitted with check valve on delivery side, metal mesh filter on suction side and electronic protection with temperature sensors directly inserted in the windings and on the delivery pipe.

Startup in compressors featuring an inverter is of the "Direct On Line" type with an inverter-controlled acceleration ramp that minimises inrush currents.

In addition to the obvious energy savings arising from greater efficiency, the use of a full inverter unit also brings advantages in terms of installation:

- For these units, the $\cos\phi$ (power factor) is always greater than 0.95, therefore making external power factor correction systems unnecessary.
- The maximum inrush current of the unit is always lower than its maximum absorbed current (calculated in the worst operating condition), therefore making the power cables and line protection devices less onerous.

All the compressors are fitted as standard with a spare oil heater and a delivery valve.

SOURCE-SIDE HEAT EXCHANGER

Shell-and-tube heat exchanger, with single water passage on tube side. Steel shell, and tube bundle made with copper tubes. The heads can be removed for tube inspection and cleaning. Victaulic couplings on water side (complete with nipple for connection).

USER-SIDE HEAT EXCHANGER

Latest generation shell and tube heat exchanger Hybrid Falling Film with two passes.

The new technology combines the features of a traditional flooded evaporator and the Falling Film evaporator, thus ensuring low approach temperatures and a low refrigerant charge.

Below is a sample cross-section of the evaporator.

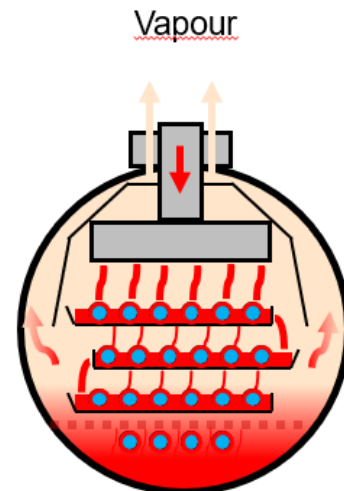

The heat exchanger consists of a steel shell insulated with closed-cell foam material, while the tube bundle is made with copper tubes. The heads can be removed for tube inspection and cleaning. Victaulic couplings on water side (complete with nipple for connection). On the hydraulic connections of the heat exchanger, there are also pipe taps for the differential pressure switch, and wells for the temperature probes.

REFRIGERANT CIRCUIT

The refrigerant circuit of the unit comprises:

- discharge valve for each compressor
- charging valves
- liquid sight glass
- replaceable solid cartridge dehydrator filter on the liquid line;
- a hermetic dehydrator filter on the oil recovery line;
- oil optical level;
- electronic expansion valve
- pressure transducers for reading the high and low pressure values and relevant evaporating and condensing temperatures
- pressure transducer and a temperature probe designed to sense the subcooling value after the condenser;
- a high pressure switch;
- a high and low pressure safety valve;
- an oil separator in the discharge line;
- oil receiver
- jet pumps for oil recovery from the evaporator.
- oil flow switch
- pressure transducer warning about oil return
- sensor warning about low oil level
- sensor warning about low fluid level in evaporator

The suction pipes in the refrigerant circuit and the heat exchanger on the user side are insulated with an extruded closed-cell expanded elastomer.

With reference to the Hybrid Falling Film technology, the refrigerant subcooling value is checked through the measurement of the temperature and pressure downline of the condenser, as shown in the picture below:

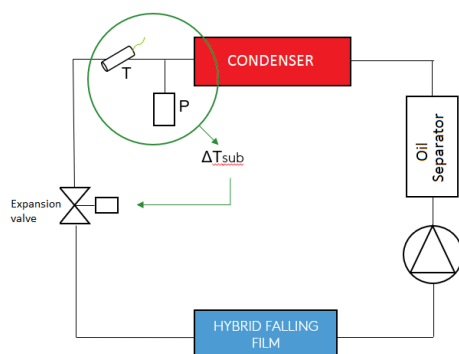

The electronic expansion valve is designed to offer enhanced stability during operation and to maximise the use of evaporation under all load conditions. This also acts as shut-off valve on the liquid line, thereby preventing hazardous refrigerant migrations during compressor stops.

The basic version does not include the R1234ze refrigerant detector. The refrigerant detector is standard equipment for the LN version.

ELECTRICAL CONTROL PANEL

The electrical control panel is made in a painted galvanized sheet-iron box with forced ventilation and IP21 protection rating.

The electrical control panel of the basic unit comprises:

- main disconnect switch
- fuses to protect the compressors and the auxiliary circuits
- compressor contactors
- phase monitor
- potential-free general alarm contacts
- single potential free operating contacts
- microprocessor controller with display accessible from the outside
- Capacitive backup battery for electronic expansion valve
- AC inverter fitted outside the panel

All the electrical cables inside the panel are numbered and the terminal board dedicated to the customer's connections is coloured orange so that it can be quickly identified in the panel.

Standard power supply of the unit is 400V/3~/50Hz

CONTROL BLUETHINK

Programmable microprocessor control, having proprietary control algorithms.

The control allows the following functions:

- Inverter management
- Vi management
- Electronic valve management
- water temperature adjustment, with outgoing water control
- freeze protection
- compressor timings
- recording of the log of all machine inputs, outputs and states
- automatic rotation of compressor starting sequence
- recording of the alarm log
- management of capacity reduction of the compressors during starting, switching off and load tracking
- management of capacity reduction of the compressors in the event of operation outside the limits

Connection resources

The control includes the following connection resources:

- RS485 serial port with Modbus protocol
- Ethernet serial port with Modbus protocol; access to integrated web server
- digital input for remote setting of state (on/off)
- digital input for setting of summer/winter mode (only for HPW version)
- digital input for selection of double set point

By default, the serial connections present as standard are enabled only for reading from BMS. Enabling of writing from BMS is to be requested when ordering.

Main functions of the webserver

As standard, the Bluethink controller integrates a web server with preloaded web page, which is accessed via password and user management on several levels.

The web page allows the following functions to be carried out (some available only for users with advanced level rights):

- display of the main characteristics of the unit such as serial number, size, refrigerant
- display of the general status of the machine: water inlet and outlet temperatures on user side and source side, mode, evaporating and condensing pressures, suction and discharge temperatures
- display of the status of compressors and electronic expansion valves
- display of graphs of the main quantities, as trends in real time and also as log data
- display of alarm log
- remote setting of (on/off)
- remote setting of set point
- remote setting of time band
- remote setting of summer/winter mode

Human-Machine Interface

The control has a graphic display that allows the following information to be displayed:

- water inlet and outlet temperature
- set temperature and differential set points
- description of alarms
- hour meter of operation and number of start-ups of the unit, the compressors and the pumps (if present)
- high and low pressure values, and relevant condensing and evaporating temperatures
- superheating at compressor suction.

For further details on available functions and on displayed information, you can refer to the specific documentation of the control.

CONTROLS AND SAFETY DEVICES

All the units are fitted with the following control and safety components:

- high pressure switch with manual reset for each compressor
- high pressure safety device with automatic reset, for a limited number of occurrences, managed by the controller via specific pressure transducer
- low pressure safety device with automatic reset, for a limited number of occurrences, managed by the controller via specific pressure transducer
- high pressure safety valve
- Low pressure safety valve
- operation probe at the outlet of the user-side heat exchanger that also acts as antifreeze probe
- thermal overload protection for compressors
- water differential pressure switch installed at the factory
- flow switch for oil level detection
- pressure differential on oil filter
- low oil level detection
- low fluid level detection in evaporator

TESTING

All the units are factory-tested and supplied complete with oil and refrigerant.

CERTIFICATIONS AND REFERENCE STANDARDS

The manufacturer has implemented and keeps the Management Systems listed below and it is certified against them:

- Quality Management System according to standard UNI EN ISO 9000;
- Environmental Management System according to standard UNI EN ISO 14000;
- Health and Safety Management System according to standard BS OHSAS 18000 (as converted into UNI EN ISO 45000).

These management systems ensure that the company puts in place any and all actions and initiatives to define and monitor the standards defined by its Management, which are stated in its Quality, Environmental and Safety policies.

To meet the safety requirements, the unit was designed and manufactured in compliance with the directives and product regulations below:

- PED Directive: safety criteria to be followed when designing pressure equipment; Units are PED-approved, cat. IV;
- Machinery Directive: safety criteria to be followed when designing machinery;
- Low Voltage Directive: safety criteria to be followed when designing electrical machine parts;
- Electromagnetic Compatibility Directive: electromagnetic compatibility criteria to be followed when designing electrical machine parts;
- WEEE Directive: criteria for product management at the end of its life cycle as waste with a view to environmental protection.

The units are manufactured, tested and checked with reference to the European standards specified in the Declaration of CE Conformity, in accordance with the requirements and procedures of our Quality System.

The installation, use and storage of units featuring mildly flammable refrigerants (A2L pursuant to standard ASHRAE 34), such as R1234ze, must meet the European standards and regulations and the local laws, where applicable.

For further details, please refer to the "Instruction manual for operation and maintenance".

Responsibilities and obligations exclusive to the installer:

- to carry out a specific risk assessment according to the European regulations/standards above and/or the local laws in order to define the necessary measures for conformity;
- to comply with the requirements and to take the measures resulting from the outcomes of the risk assessment, pursuant to the relevant regulations and standards.

VERSIONS

Alongside the basic version of the unit, there are the following versions

OH: non-reversible heat pump

This is a heat pump for heating only. Compared to the basic version, both user-side and source-side heat exchangers are insulated.

HPW: reversible heat pump on water side.

This reversible heat pump is suitable for applications in which the user-side circuit and the source-side circuit can be exchanged with each other. Therefore, the fitter must make provision for a system of valves that will allow exchange of the two hydraulic circuits. If the seasonal mode change is carried out via remote signal or BMS, the unit can control motor-driven reversing valves (not supplied) so as to make this operation fully automatic.

Compared to the basic version, both user-side and source-side heat exchangers are insulated.

OPTIONS

/LN: low noise version

The unit includes a soundproofing compartment on the compressor consisting of a rigid outer cowling made of galvanised and painted sheet metal (RAL 7035), lined with sound absorbing matting with high acoustic impedance material in between.

The compressor compartment is supplied with a R1234ze refrigerant detector and a pushing fan designed to take the air from outside the compartment and push it inside the compartment until it comes out of the outlet grille specifically installed on the compartment side opposite the fan.

If the gas detector senses leaking refrigerant, the machine electronic controller causes all the fitted and operating compressors to instantly stop and an alarm message to appear on the display.

In addition, the alarm signal is provided on a clean contact in the terminal board of the electrical panel of the unit: this allows, after prior preparation by the installer, to disconnect the unit from voltage to prevent any source of ignition.

/DC: unit with total recovery condenser

In addition to the basic version, the following elements are included in the chiller unit only:

- a recovery section of condensation heat (100%), featured inside the condenser;
- a temperature probe at the inlet of the heat recovery heat exchanger
- potential free contact in the electrical control panel for activation of heat recovery. When required by the system, through the closing of a contact, the controller automatically manages activation of heat recovery. Heat recovery management is carried out through a control on the temperature of the return water. The controller also automatically manages safety deactivation of heat recovery, if the condensing pressure becomes too high, and switches to using the source-side heat exchanger.

DESCRIPTION OF ACCESSORIES

Some accessories may be incompatible with each other even if not expressly indicated.

Refrigerant circuit accessories

VM2 Condensation control with 2-way modulating valve

The accessory includes the supply of a 2-way modulating valve complete with servo control to be installed on the source-side hydraulic circuit (installation by the customer). The servo control is controlled via a 0-10V signal from the control depending on the condensing pressure.

This accessory is to be used in applications where it is beneficial, when possible, to reduce the total flow rate of water coming from the source (for example, when well water is used). When the unit reaches the setpoint, the valve will be forced to close.

Accessory supplied loose.

VM3 Condensation control with 3-way modulating valve

The accessory includes the supply of a 3-way modulating valve complete with servo control to be installed on the source-side hydraulic circuit (installation by the customer). The servo control is controlled via a 0-10V signal from the control depending on the condensing pressure.

This accessory is to be used in applications where it is beneficial, when possible, to reduce the flow rate of water sent to the source-side heat exchanger (for example, when water from a loop is used). When the unit reaches the set point, the valve will be forced to total recirculation.

Accessory supplied loose.

SCU Cumulative 0-10V signal for condensation control

This accessory requires a 0-10V output in the terminal board to carry out condensation control through a device outside the machine (2-way valve, 3-way valve, inverter-controlled pump). The signal is linked to the condensing pressure.

The signal is cumulative and therefore the accessory is suitable for combination on units in which there is a single condensation control device located on the common branch of the source.

Incompatible with condensation control with modulating valve.

DVS Double safety valve

With this accessory, instead of each individual safety valve per circuit, there is a "candelabrum" with two safety valves and a diverter valve for choosing the valve in operation. This allows the safety valves to be replaced without having to drain the machine and without having to stop it.

MAFR Pressure gauges

The operating pressures of each circuit of the unit can be displayed on the control by accessing the relevant screens. Also, the machine can be fitted with pressure gauges (two for each circuit) installed in a clearly visible position. These allow reading in real time of the working pressures of the refrigerant gas on the low pressure side and on the high pressure side of each refrigerant circuit.

RUBA Compressor suction valves

The valves situated on the suction side of the compressors allow the compressor to be isolated from the rest of the refrigerant circuit, so making the maintenance operations quicker and less invasive.

The compressor discharge valve is standard on all compressors

BK Brine Kit LGW

This accessory is compulsory if a water temperature set point lower than +5°C is used (if the unit is provided with double set point or variable set point, the lower set point is considered).

The accessory consists of increased insulation and suitable sizing and calibration of some components.

The inlet and outlet temperatures of the user-side exchanger must be given on ordering to allow correct setting of the alarm parameters and verification of the sizing of the expansion valve.

The cooling set point can then be changed by the customer in an interval that, compared to the set point given on ordering, ranges from -1K up to the maximum temperature allowed by the above-stated operating limits.

The unit will be optimized to work at the set point temperature given on ordering. For different set points, the cooling capacity provided and the level of efficiency of the machine could decrease and move away from these conditions.

HWTE Evaporator high temperature water kit

This accessory is compulsory if evaporator water temperature set point higher than or equal to +12°C is used (if the unit is provided with double set point or variable set point, the higher set point is considered).

The accessory consist of a dedicated evaporator, designed for higher water temperatures

This accessory can modify unit dimensions

The inlet and outlet temperatures of the user-side exchanger must be given on ordering to allow correct setting of the alarm parameters and verification of the sizing of the expansion valve.

The cooling set point can then be changed by the customer in an interval that, compared to the set point given on ordering, ranges from -1K up to the maximum temperature allowed by the above-stated operating limits.

The unit will be optimized to work at the set point temperature given on ordering. For different set points, the cooling capacity provided and the level of efficiency of the machine could decrease and move away from these conditions.

Hydraulic circuit accessories

CFC Flanged hydraulic connections + counterflanges

Depending on the version of the unit, flanges and counterflanges are supplied for:

- user side
- on the source side.
- recovery side

Accessory supplied loose.

FVF FLOWZER VFPP – Kit for variable flow rate primary circuit pump with bypass valve included

Bluethink solution for a variable flow rate system, consisting solely of a user-side primary circuit.

Flowzer VFPP includes:

- a pressure transducer installed at the ends of the user-side exchanger (Δp_e)
- a dedicated control system, installed at the factory in the electrical control panel of the unit (Sc)
- a modulating bypass valve with servo-motor supplied separately with it (V_{bp}), supplied loose (installation by the customer)
- two system pressure transducers (Δp_p) supplied separately (installation by the customer)

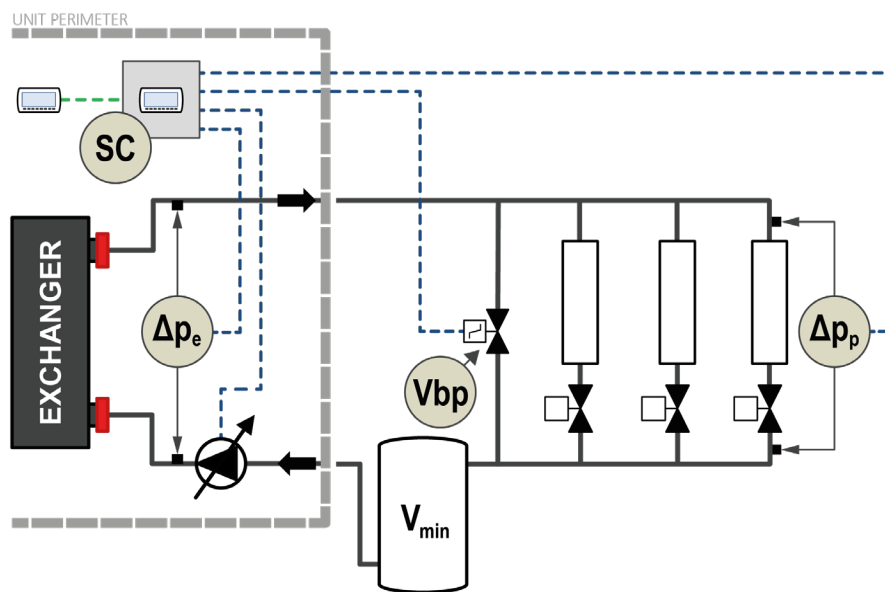

The components above and the pump inverter must be selected at the time of the pre-sale agreements, depending on the features of the system. This has an impact on the quotation of the option and on the supply terms of the concerned components.

In particular, the unit includes an additional control system, equipped with an advanced algorithm, which interacts with the main advanced Bluethink controller.

Flowzer VFPP has the advantage of:

- implementing an innovative design, which is alternative to the classic system based on fixed flow-rate primary circuit plus secondary circuit
- being ideal for new or entirely redesigned systems, especially for comfort applications
- having a variable flow system, with maximum energy saving
- simplifying the layout of the user circuit
- limiting the capex of the system
- performing a reliable check

The Flowzer VFPP system controller uses an advanced algorithm that enables prevention of unnecessary waste of energy and hunting by the inverter and the bypass valve.

The capex of the system is also reduced thanks to:

- small internal footprint, due to the simplified layout

The operating principle can be summarized as follows:

- Flowzer VFPP carries out constant control of the discharge head
- the controller modulates the pump speed according to the signal detected by the system transducers Δp_p
- as the demand from the system goes down, the pump speed will be reduced.
- the pump speed can be reduced until it reaches the minimum allowed flow rate on the heat exchanger of the unit
- this flow rate is indirectly monitored through the losses detected by the differential pressure transducer Δp_e
- When the minimum allowed flow rate threshold is exceeded, the control system will open the bypass valve V_{bp} to recirculate the flow rate that is not required by the system, but is necessary to guarantee the minimum flow rate to the heat exchanger.

In the required minimum load condition (that is, with all system terminals switched off) the necessary minimum volume (V_{min}) must be ensured by the relevant tank to be installed between the unit and the separator or the bypass pipe.

The bypass valve V_{bp} is controlled through a 0-10 V signal and must therefore be installed within 30 m of the unit.

The pressure transducers of the system Δp_p provide a 4-20 mA signal and require two 1/4" female fittings. These transducers must be installed within 200 m of the unit, near the system terminal that is affected by the highest line head losses or in any case in a position where it is possible to measure an adequate pressure value.

Further details can be found in the relevant manual.

FVPS FLOWZER VPS – Kit for variable flow rate pump with temperature sensors

Bluethink solution for a variable flow rate system, consisting of a primary circuit plus secondary circuit.

Flowzer VPS includes:

- a differential pressure transducer, installed at the factory at the ends of the user-side heat exchanger of the unit (Δp_e)
- a dedicated control system, installed at the factory in the electrical control panel of the unit (Sc)
- two system temperature sensors (T) - supplied separately; installation by the customer

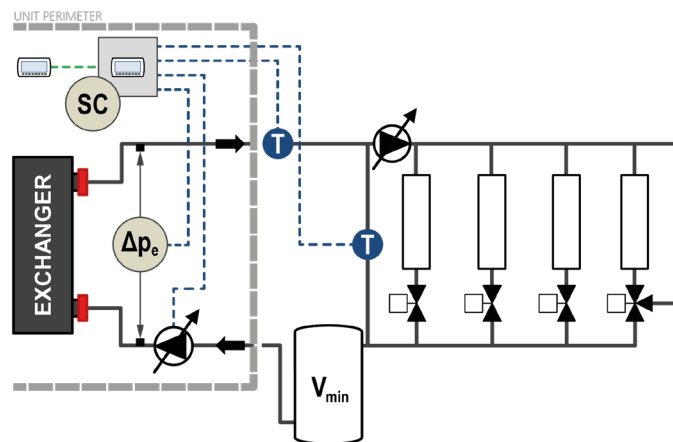

The components above and the pump inverter must be selected at the time of the pre-sale agreements, depending on the features of the system. This has an impact on the quotation of the option and on the supply terms of the concerned components.

In particular, the unit includes an additional control system, equipped with an advanced algorithm, which interacts with the main advanced Bluethink controller.

Flowzer VPS has the advantage of:

- being ideal for renovations of existing systems, especially for comfort applications
- achieving a complete variable flow system, with maximum energy saving
- implementing a flexible design, e.g. for scalable or multi-zone systems

The maximum energy saving is achieved thanks to the advanced algorithm, which prevents hunting by the inverter and balances the pump speed and the recirculation flow rate to a minimum.

With refurbishments, the system's capex is limited to the unit and its commissioning.

The dimensions of the inverter of the unit and of the pump module can be favoured by the low design discharge head of the primary circuit.

The operating principle can be summarized as follows:

- Flowzer VPS performs a smart check of the flow rate in the primary circuit and balances it with the flow rate in the secondary circuit.
 - the system controller modulates the pump speed according to the condition detected by the system sensors T
 - if the system terminals are switched off, the flow rate of the secondary circuit will decrease; therefore the direction of flow is detected indirectly as temperature difference by the system sensors through the separator or the bypass pipe
 - The check thus contributes to reducing the speed of the primary pump until the min. flow threshold in the heat exchanger of the unit is exceeded.
 - this flow rate is indirectly monitored through the losses detected by the differential pressure transducer Δp_e
- In the required minimum load condition (that is, with all system terminals switched off) the necessary minimum volume (V_{min}) must be ensured by the relevant tank to be installed between the unit and the separator or the bypass pipe.

The temperature sensors of the system T provide a 4-20 mA signal and require 1/2" female fittings.

Further details can be found in the relevant manual.

PVX Variable flow setup for HYZER X

The dedicated HYZER X controller is designed to manage the different units, devices and components that make up a hydronic system.

Systems featuring this controller require that the PVX option be installed at the ends of the user-side heat exchanger of a differential pressure transducer so that the machine is set up for variable flow rate control.

This option is mandatory in all units making up the system.

For additional information on the product HYZER X, please refer to the specific technical catalogue.

VIX Shut-off valves for systems with external pumps for HYZER X

Systems featuring the HYZER X controller enable the selection of the shut-off valve used in systems that have an external pumping unit.

Two shut-off valves are supplied together with water/water machines that need to be installed on the source- and user-side circuits of the unit (installation by customer).

FLMX User-side flow meter for HYZER X

Systems featuring the HYZER X controller enable the selection of the flow meter option to calculate the flow rate and the performances of the units.

The option is supplied with the system for installation on the user side (installation by customer).

Electrical accessories

LIID Limitation of the current absorbed by digital input

When this accessory is requested, a digital input is prepared in the terminal board to activate the forced capacity reduction of the unit to a set fixed level.

This accessory is useful when there is a need to necessarily limit the power absorbed by the unit as regards particular conditions.

We point out that, in some conditions (for example, during hourly compressor rotation procedures), the controller could force the unit to operate at full capacity for limited periods of time.

SETD Double set point from digital input

The accessory allows you to preset two different operating set points and manage the change from one to the other through a digital signal.

The set point temperatures must be specified when ordering. For optimization of the unit, reference will be made to the lower set point in chiller mode and the higher set point in heat pump mode.

Unless otherwise specified in the order, the controller will be set at the factory with the following temperatures:

- in chiller mode, set point 1 to 7°C and set point 2 to 12°C
- in heat pump mode (only for HPW and OH units) set point 1 at 45°C and set point 2 at 40°C

Maximum acceptable temperature difference between two set points 10°C

CSP Set point compensation depending on external air temperature

For units fitted with this accessory, the set point of the unit is set so that it can vary between two values, a maximum and a minimum, depending on the external air temperature. The compensation ramp and the maximum and minimum values of the set point can be changed by the user.

Unless otherwise specified in the order, the controller will be set to implement a positive compensation logic according to the temperatures shown in the following diagrams:

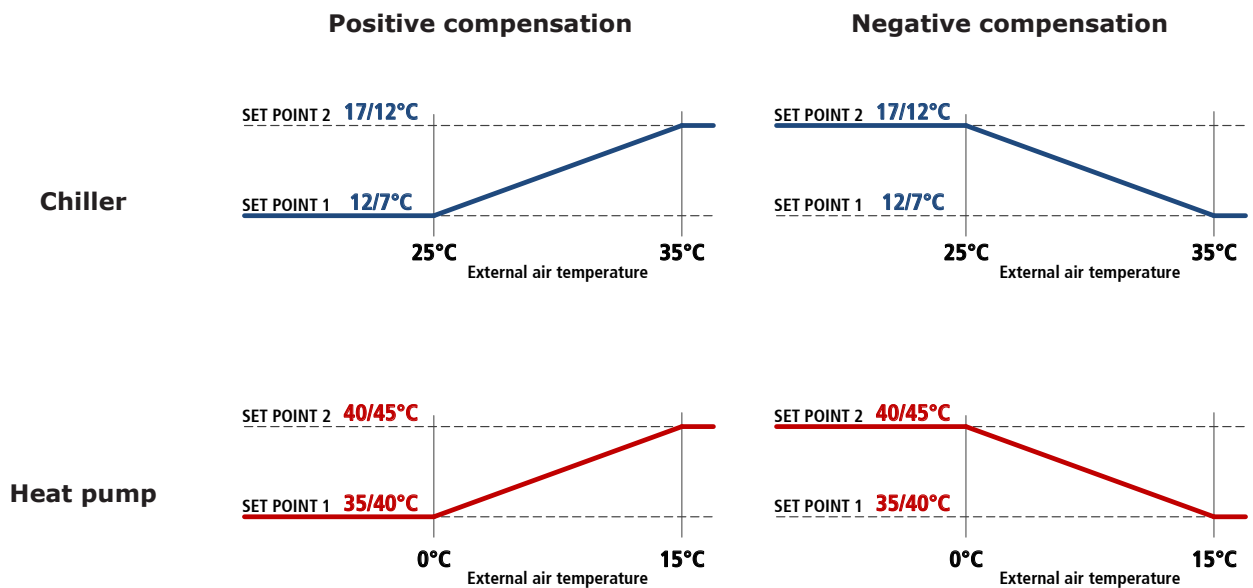

IA Automatic circuit breakers (instead of fuses)

This accessory requires the installation of automatic circuit breakers, instead of fuses, for the protection of auxiliary loads. Also, the same accessory uses automatic circuit breakers with adjustable thermal overload protection to protect the compressors.

SETV Variable set point with remote signal

The accessory allows the set point to be varied continuously between two preset values, a maximum and a minimum, depending on an external signal that can be of the 0-1V, 0-10V or 4-20mA type.

The set point temperatures and the type of signal to use for the adjustment must be specified when ordering. For optimization of the unit, reference will be made to the lower set point in chiller mode and the higher set point in heat pump mode.

Unless otherwise specified in the order, the controller will be set at the factory with 0-10V analogue input and with the following temperatures:

- in chiller mode, 0V will correspond to a set point of 7°C and 10V will correspond to a set point of 12°C
- in heat pump mode (only for HPW and OH units), 0V will correspond to a set point of 45°C and 10V will correspond to a set point of 40°C

Maximum acceptable temperature difference between two set points 10°C

DAM Double power supply with manual switching

A manual switch to which to connect two separate power supply lines (for example, one from the mains power line and one from the uninterruptible power supply unit) is installed in the electrical control panel of the unit.

The switching from one line to another is manual and obligatorily requires passing through the OFF position.

DAA Double power supply with automatic switching

A motor-driven automatic switch to which to connect two separate power supply lines (for example, one from the mains power line and one from the uninterruptible power supply unit) is installed in the electrical control panel of the unit.

The switching from one line to another is automatic and obligatorily requires passing through the OFF position.

When this accessory is requested, the power supply of the unit must compulsorily include neutral.

ENM Energy meter

The accessory allows the main electrical quantities (including voltage, current, power) to be read on the three phases, via current transformer.

This accessory communicates with the BlueThink controller to supervise the monitored data. The values measured are then made available through the unit display and the web server.

ENML Energy meter with current limiter

The accessory allows the main electrical quantities (including voltage, current, power) to be read on the three phases, via current transformer.

This accessory communicates with the BlueThink controller to supervise the monitored data. The values measured are then made available through the unit display and the web server.

This accessory is designed to limit the maximum current the unit can absorb. The controller instantly checks the absorption levels and, where necessary, it applies a forced capacity reduction that keeps the absorbed current value below the stored threshold.

GFC FC/NG management

This option is available only for the basic model (chiller).

The option includes configuration of the BlueThink controller of the unit, in order to carry out the free-cooling mode, without using glycol.

The option also includes integration in the machine of: free-cooling pump relay, consent for external dry cooler, system return probe and dry-cooler inlet and outlet probes.

The components required for making the system, and also the hydraulic and electrical connections to the unit, are to be provided by the customer.

More specifically, the system will consist of:

- a water-water heat exchanger that carries out the separation between the source side (glycol) and the user side (non-glycol).
- a 3-way modulating valve that feeds the free cooling circuit and carries out condensation control when the unit is working in mixed chiller/free cooling mode.
- a source-side pump

-
- R1PR Relay for management of 1 external heat recovery-side pump**
This accessory can be requested for units without heat recovery pumps (for DC units) and allows a pump outside the machine to be controlled.
- R2PR Relay for management of 2 external heat recovery-side pumps**
This accessory can be requested for units without heat recovery pumps (for DC units) and allows two pumps outside the machine to be controlled with a running/stand-by logic by implementing a rotation on the hours of operation.
- R1PU Relay for management of 1 external user-side pump**
This accessory can be requested for units without user-side pumps and allows a pump outside the machine to be controlled.
- R2PU Relay for management of 2 external user-side pumps**
This accessory can be requested for units without user-side pumps and allows two pumps outside the machine to be controlled with a running/stand-by logic by implementing a rotation on the hours of operation.
- RE1S Relay for management of 1 external source-side pump**
This accessory can be requested for units without source-side pumps and allows a pump outside the machine to be controlled.
- RE2S Relay for management of 2 external source-side pumps**
This accessory can be requested for units without source-side pumps and allows two pumps outside the machine to be controlled with a running/stand-by logic by implementing a rotation on the hours of operation.
- RMMT Maximum and minimum voltage relay**
This accessory constantly monitors the voltage value and the unit's power supply phase sequence. If the supply voltage does not fall within the set parameters or there is a phase reversal, an alarm is generated that stops the machine to prevent damage to its main parts
- FARE Fast Restart**
The Fast Restart accessory enables the controller to carry out a fast restart of the unit following a blackout, in order to reduce machine down times to a minimum.
This accessory requires the provision of a power supply line dedicated to the controller (uninterruptible power supply unit installed by the customer) and a maximum and minimum voltage relay in the electrical control panel. In this way, the controller of the unit will always remain powered even during a blackout.
Once the main power supply returns after a blackout, the starting of the first compressor takes place within 60 seconds and the full capacity of the unit is reached in about 180 seconds (a time that depends on the number of compressors and the instant load level).
In order to protect component service life, the controller may carry out the Fast Restart procedure no more than 3 times in an hour and 5 times in one day.
Also, to make it easier to carry out any maintenance on the power supply line dedicated to the controller, there is a selector switch inside the electrical control panel to allow the controller to be powered directly from the main power supply of the machine.
Includes "Maximum and minimum voltage relay".
- TERM Remote-controlled user terminal panel**
This accessory allows the terminal normally situated on the machine to be replicated on a support situated at a distance. It is particularly suitable when the unit is placed in an area that is not easily accessible.
The accessory is supplied loose and is to be installed by the customer at a maximum distance of 120m from the unit. We advise using a cable of the following type: "TECO O.R. FE 2x2xAWG24 SN/ST/PUR".
For this accessory, there is a dedicated serial port.

PBA BACnet protocol over IP (Ethernet)

The controller is set for use, in read and write mode, of the BACnet port on IP protocol.

By default, the programming gives read-only access to the control of the unit. Enabling of read/write access should be requested when ordering.

PSN SNMP protocol

The accessory consists of a gateway that allows Ethernet connection to a SNMP manager supervision system. The use of this accessory causes the RS485 serial port to be unavailable.

GLO Modbus Lonworks Gateway

With this accessory, a RS485/Lon gateway is installed inside the electrical control panel.

By default, the programming gives read-only access to the control of the unit. Enabling of read/write access should be requested when ordering.

SMAR Smartlink

This accessory makes it possible to connect the controller of the unit with the controller of a Swegon GOLD™ air handling unit via a simple serial cable, so allowing their operating logics to be merged into a single consciousness that pursues the maximum energy efficiency of the system. The RS485 serial interface is already included and dedicated to connection with Swegon units.

The option is incompatible with:

- double set point
- variable set point with remote signal
- summer/winter selection by digital input
- set point compensation depending on external air temperature
- multilogic
- all communication protocols.

SW4P Network switch with 4 ports

The accessory includes installation in DIN rail of a professional 4-port network switch. Requires Blueye via Ethernet.

SW8P Network switch with 8 ports

The accessory includes installation in DIN rail of a professional 8-port network switch.

Requires Blueye via Ethernet.

WIFI Wi-Fi

The accessory includes the supply of a Hot Spot WiFi already installed, wired and configured, complete with antenna. This accessory requires the Ethernet port of the controller to be available or, alternatively, a network switch with at least one available port to be present in the machine.

FMx Multilogic Function

The Multilogic function allows management of up to 32 units equipped with advanced Bluethink controller and connected in hydraulic parallel with each other.

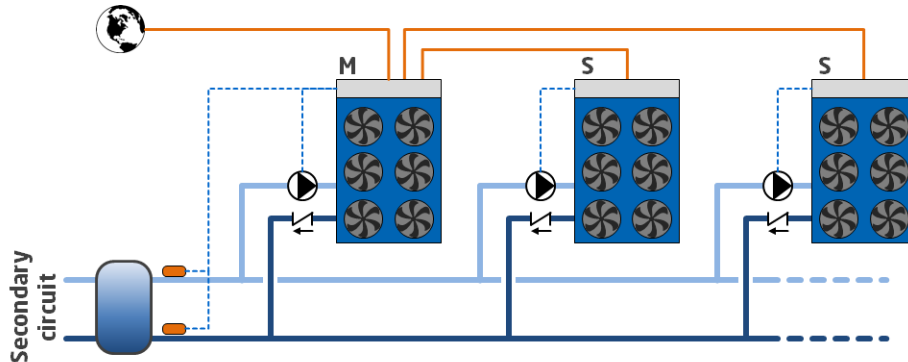

On the basis of the information recorded by the temperature probes installed on the delivery and return manifolds of the system, with the master unit, a capacity request is generated that is distributed among the units connected in the Multilogic network according to settable priority and optimization logics.

If communication between the units fails or if the master is off-line, the slave units can continue to work according to the set thermoregulation parameters.

The connected units can be different from each other, in terms of capacity and set-up, provided the following rules are complied with:

- if there are both chiller units and heat pumps in the Multilogic network, the Master unit must obligatorily be one of the HP units
- if there are both free cooling and non free-cooling units in the Multilogic network, the Master unit must obligatorily be one of the free-cooling units.

The Multilogic function that can be requested with the unit can be:

- **FM0:** Multilogic function for Slave unit
- **FM2:** Multilogic function for Master unit for managing up to 2 Slaves
- **FM6:** Multilogic function for Master unit for managing up to 6 Slaves

If you need to connect more than 6 slaves (up to 31), you can ask for a quotation from our sales department.

For the slave units, the accessory requires:

- programming of the unit as slave of a system of machines in Multilogic network

For the master units, the accessory requires:

- programming of the unit as master of a system of machines in Multilogic network
- entering of the parameters necessary for connection with the individual slave units
- installation in the electrical control panel of a network switch to allow the units to be connected in a LAN network.
- the supply of 2 temperature probes to be positioned on the delivery and return manifold of the system (supplied separately with it, installation and wiring by the customer)

The connection between the master unit and the slave units made with a CAT cable. 5E/UTP (prepared by the customer) with RJ45 connectors. Maximum cable length 100m.

For further details, please refer to the controller manual.

Other accessories

AG Rubber anti-vibration mounts

These allow you to reduce the vibrations transmitted from the unit to the surface it is standing on. Accessory supplied loose.

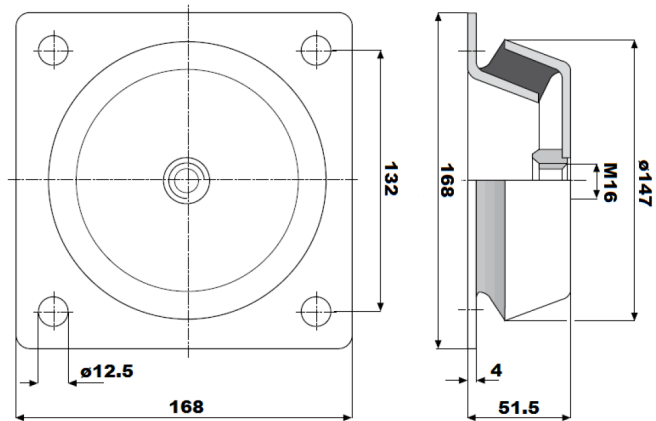

AM Spring anti-vibration mounts

These allow you to reduce the vibrations transmitted from the unit to the surface it is standing on. Accessory supplied loose.

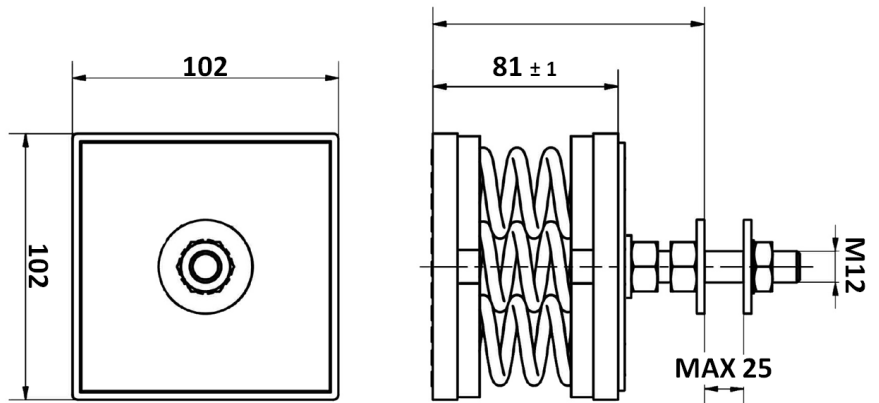

FLUS Flow switch

As an alternative to the differential pressure switch (standard flow sensor), it is possible to request the paddle flow switch as accessory. This detects when there is no water flow to the user-side exchanger and sends a signal to the control of the unit that will stop the compressors to prevent damage to the exchangers. The flow switch is supplied loose (installation by the customer) and replaces the water differential pressure switch (standard).

GABB Packaging in wooden crate

The unit is protected by a custom-made wooden cage, including a wooden sled designed for loading into containers and a fixing system. The accessory can be used for container shipping. Loading on containers must be carried out at the factory. The accessory is incompatible with "Skid for shipping in containers".

KFW Water filter kit

To protect the elements of the hydraulic circuit (in particular, the exchangers), there are Y filters that can stop and settle the particles that are normally present in the water flow and would otherwise settle in the more delicate parts of the hydraulic circuit and damage its heat exchange capacity.

The kit involves the supply of a filter for each exchanger present in the machine.

Installation of the water filter is mandatory even when it is not supplied as an accessory.

Accessory supplied loose.

Depending on the version of the unit, user side and source side filters are supplied, and for DC version units, heat recovery side filters are also supplied.

SLCO Skid for shipping in container

The accessory provides for the installation of a wooden sled for loading and a fixing system inside the container by a strap. The accessory must be used for shipping in container. Loading on containers must be carried out at the factory. The accessory is incompatible with "Packaging in wooden crate".

TECHNICAL SPECIFICATIONS

OMEGA SKY Xi LGW

			19.1	21.1	26.1	30.1	36.1	39.1	45.1	54.1	61.1	73.1
Cooling												
Refrigeration capacity	(1)	kW	184	221	264	295	337	383	431	524	592	684
Total absorbed power	(1)	kW	38	44	52	58	66	75	83	100	112	137
EER	(1)		4,84	5,04	5,06	5,08	5,1	5,14	5,17	5,26	5,28	5
ESEER	(10)		7,02	7,31	7,4	7,49	7,65	7,76	7,71	7,73	7,67	6,8
Eurovent efficiency class	(1)		B	B	A	A	A	A	A	A	A	B
User-side heat exchanger												
Quantity		n°	1	1	1	1	1	1	1	1	1	1
Water flow rate	(1)	m ³ /h	32	38	45	51	58	66	74	90	102	118
Head loss	(1)	kPa	30	31	33	29	30	30	31	32	30	28
Source-side heat exchanger												
Quantity		n°	1	1	1	1	1	1	1	1	1	1
Water flow rate	(1)	m ³ /h	38	46	54	60	69	79	88	107	121	141
Head loss	(1)	kPa	15	15	14	14	14	15	13	16	21	24
Compressors												
Compressors/Circuits		n°/n°	1/1	1/1	1/1	1/1	1/1	1/1	1/1	1/1	1/1	1/1
Minimum capacity reduction step	(7)	%	0,25	0,25	0,25	0,25	0,25	0,25	0,25	0,25	0,25	0,25
Refrigerant charge	(6)	kg	58	59	85	90	88	88	119	122	145	144
Noise levels												
Sound power lev.	(4)	dB(A)	99	99	100	100	101	101	102	102	104	106
Sound pressure lev.	(5)	dB(A)	81	81	82	82	83	82	83	83	85	87
Sound power levels LN	(4)	dB(A)	94	94	95	95	96	96	97	97	99	101
Sound pressure levels LN	(5)	dB(A)	76	76	77	77	78	77	78	78	80	82
Dimensions and weights**												
Length		mm	3700	3700	3800	3800	3800	3900	3900	4100	4150	4250
Depth		mm	1500	1500	1550	1550	1550	1550	1550	1670	1670	1850
Height		mm	2050	2050	2100	2100	2100	2150	2150	2300	2400	2400
Operating weight		kg	2215	2335	2694	2832	2987	3381	3509	4260	4742	5460

(1) Source-side heat exchanger inlet/outlet water temperature 30/35°C; user-side heat exchanger inlet/outlet water temperature 12/7°C. Values compliant with standard EN 14511

(4) Unit operating at nominal operating capacity, without any accessories, with source/side heat exchanger inlet-outlet water temperature 30/35°C and user-side heat exchanger inlet/outlet water temperature 12/7°C. Values obtained from measures taken according to standard ISO 3744 and to the Eurovent certification programme where applicable. Binding values. See NOISE LEVELS section.

(5) Values obtained from the sound power level (conditions in note 4), related to a distance of 1 m from the unit in free field with directivity factor Q=2. Non-binding values.

(6) Theoretical values referred to the basic unit (without DC). The amount of gas actually charged in the unit may differ.

(7) Approximate value. The minimum capacity reached by the unit depends on the operating conditions. The value shown may not be suitable for calculating the minimum volume of water: to do this, consult the "Minimum water content in the system" section.

(10) Former Eurovent's seasonal efficiency index. Value not certified by Eurovent from 2019. Reference: base unit, without any accessories

** Basic unit without included accessories

OMEGA SKY Xi LGW HPW

			19.1	21.1	26.1	30.1	36.1	39.1	45.1	54.1	61.1	73.1
Cooling												
Refrigeration capacity	(1)	kW	184	221	264	295	337	383	431	524	592	684
Total absorbed power	(1)	kW	38	44	52	58	66	75	83	100	112	137
EER	(1)		4,84	5,04	5,06	5,08	5,1	5,14	5,17	5,26	5,28	5
ESEER	(10)		7,02	7,31	7,4	7,49	7,65	7,76	7,71	7,73	7,67	6,8
Eurovent efficiency class	(1)		B	B	A	A	A	A	A	A	A	B
Heating												
Heating capacity	(2)	kW	200	238	284	317	366	416	466	567	637	726
Total absorbed power	(2)	kW	47	54	64	71	81	91	102	122	138	167
COP	(2)		4,27	4,4	4,42	4,44	4,5	4,57	4,57	4,63	4,63	4,36
Eurovent efficiency class	(2)		B	B	B	B	A	A	A	A	A	B
Evaporator												
Quantity		n°	1	1	1	1	1	1	1	1	1	1
Water flow rate	(1)	m³/h	32	38	45	51	58	66	74	90	102	118
Head loss	(1)	kPa	30	31	33	29	30	30	31	32	30	28
Water flow rate	(2)	m³/h	44	53	63	71	82	94	105	128	144	161
Head loss	(2)	kPa	60	62	65	58	59	59	63	64	60	58
Condenser												
Quantity		n°	1	1	1	1	1	1	1	1	1	1
Water flow rate	(1)	m³/h	38	46	54	60	69	79	88	107	121	141
Head loss	(1)	kPa	15	15	14	14	14	15	13	16	21	24
Water flow rate	(2)	m³/h	34	41	49	55	63	71	80	98	110	125
Head loss	(2)	kPa	13	13	12	12	12	13	11	14	18	21
Compressors												
Compressors/Circuits		n°/n°	1/1	1/1	1/1	1/1	1/1	1/1	1/1	1/1	1/1	1/1
Minimum capacity reduction step	(7)	%	25%	25%	25%	25%	25%	25%	25%	25%	25%	25%
Refrigerant charge	(6)	kg	58	59	85	90	88	88	119	122	145	144
Noise levels												
Sound power lev.	(4)	dB(A)	99	99	100	100	101	101	102	102	104	106
Sound pressure lev.	(5)	dB(A)	81	81	82	82	83	82	83	83	85	87
Sound power levels LN	(4)	dB(A)	94	94	95	95	96	96	97	97	99	101
Sound pressure levels LN	(5)	dB(A)	76	76	77	77	78	77	78	78	80	82
Dimensions and weights**												
Length		mm	3700	3700	3800	3800	3800	3900	3900	4100	4150	4250
Depth		mm	1500	1500	1550	1550	1550	1550	1550	1670	1670	1850
Height		mm	2050	2050	2100	2100	2100	2150	2150	2300	2400	2400
Operating weight		kg	2215	2335	2694	2832	2987	3381	3509	4260	4742	5460

- (1) Source-side heat exchanger inlet/outlet water temperature 30/35°C; user-side heat exchanger inlet/outlet water temperature 12/7°C. Values compliant with standard EN 14511
- (2) Source-side heat exchanger inlet/outlet water temperature 10/7°C; user-side heat exchanger inlet/outlet water temperature 40/45°C. Values compliant with standard EN 14511
- (4) Unit operating at nominal operating capacity, without any accessories, with source/side heat exchanger inlet-outlet water temperature 30/35°C and user-side heat exchanger inlet/outlet water temperature 12/7°C. Values obtained from measures taken according to standard ISO 3744 and to the Eurovent certification programme where applicable. Binding values. See NOISE LEVELS section.
- (5) Values obtained from the sound power level (conditions in note 4), related to a distance of 1 m from the unit in free field with directivity factor Q=2. Non-binding values.
- (6) Theoretical values referred to the basic unit (without DC). The amount of gas actually charged in the unit may differ.
- (7) Approximate value. The minimum capacity reached by the unit depends on the operating conditions. The value shown may not be suitable for calculating the minimum volume of water: to do this, consult the "Minimum water content in the system" section.
- (10) Former Eurovent's seasonal efficiency index. Value not certified by Eurovent from 2019. Reference: base unit, without any accessories

** Basic unit without included accessories

OMEGA SKY Xi LGW OH

			19.1	21.1	26.1	30.1	36.1	39.1	45.1	54.1	61.1	73.1
Heating												
Heating capacity	(2)	kW	200	238	284	317	366	416	466	567	637	726
Total absorbed power	(2)	kW	47	54	64	71	81	91	102	122	138	167
COP	(2)		4,27	4,4	4,42	4,44	4,5	4,57	4,57	4,63	4,63	4,36
Eurovent efficiency class	(2)		B	B	B	B	A	A	A	A	A	B
Source-side heat exchanger												
Quantity		n°	1	1	1	1	1	1	1	1	1	1
Water flow rate	(2)	m³/h	44	53	63	71	82	94	105	128	144	161
Head loss	(2)	kPa	60	62	65	58	59	59	63	64	60	58
User-side heat exchanger												
Quantity		n°	1	1	1	1	1	1	1	1	1	1
Water flow rate	(2)	m³/h	34	41	49	55	63	71	80	98	110	125
Head loss	(2)	kPa	13	13	12	12	12	13	11	14	18	21
Compressors												
Compressors/Circuits		n°/n°	1/1	1/1	1/1	1/1	1/1	1/1	1/1	1/1	1/1	1/1
Minimum capacity reduction step	(7)	%	25%	25%	25%	25%	25%	25%	25%	25%	25%	25%
Refrigerant charge	(6)	kg	58	59	85	90	88	88	119	122	145	144
Noise levels												
Sound power lev.	(4)	dB(A)	99	99	100	100	101	101	102	102	104	106
Sound pressure lev.	(5)	dB(A)	81	81	82	82	83	82	83	83	85	87
Sound power levels LN	(4)	dB(A)	94	94	95	95	96	96	97	97	99	101
Sound pressure levels LN	(5)	dB(A)	76	76	77	77	78	77	78	78	80	82
Dimensions and weights**												
Length		mm	3700	3700	3800	3800	3800	3900	3900	4100	4150	4250
Depth		mm	1500	1500	1550	1550	1550	1550	1550	1670	1670	1850
Height		mm	2050	2050	2100	2100	2100	2150	2150	2300	2400	2400
Operating weight		kg	2215	2335	2694	2832	2987	3381	3509	4260	4742	5460

(2) Temperature of input-output water to/from source-side heat exchanger 10/7°C; temperature of input-output water to/from user-side heat exchanger 40/45°C. Values compliant with standard EN 14511

(4) Unit operating at nominal operating capacity, with no options of any kind, with source-side heat exchanger input/output water temperature of 10/7°C and user-side heat exchanger water inlet-outlet temperature of 47/55°C. Climate profile Average, with reference to the 2013/813 regulation and the EN 14825 standard.

(5) Values obtained from the sound power level (conditions: note 4), related to a distance of 1 m from the unit in free field with directivity factor Q=2. Non-binding values.

(6) Theoretical values referred to the basic unit (without DC). The amount of gas actually charged in the unit may differ.

(7) Approximate value. The minimum capacity reached by the unit depends on the operating conditions. The value shown may not be suitable for calculating the minimum volume of water: to do this, consult the "Minimum water content in the system" section.

** Basic unit without included accessories

ECODESIGN

INTRODUCTION

The Ecodesign/ErP Directive (2009/125/EC) lays down new standards for more efficient energy use.

The Directive contains various regulations; as regards chiller products and heat pumps, the regulations of interest are the following:

- Regulation 2013/813, for small heat pumps ($P_{\text{design}} \leq 400$ kW)
- Regulation 2016/2281, for chillers and heat pumps with $P_{\text{design}} > 400$ kW
- Regulation 2013/811, for heat pumps with $P_{\text{design}} \leq 70$ kW.

The last-mentioned regulation (2013/811) regards the labelling (Ecolabel certification) of small heat pumps.

The other two regulations (2013/813 and 2016/2281) set seasonal efficiency targets that the products must comply with to be sold and installed in the European Union (essential requirement for CE marking).

These efficiency limits are defined through ratios, which are respectively:

- η_{sh} (SCOP), with reference to regulation 2013/813
- η_{sc} (SEER) for comfort applications and SEPR for process applications, with reference to regulation 2016/2281.

As regards regulation 2016/2281, with effect from 1st January 2021, the required minimum efficiency limit will be raised (Tier 2) from the current threshold (Tier 1).

The figure below schematically illustrates the correspondence between product and reference energy ratio.

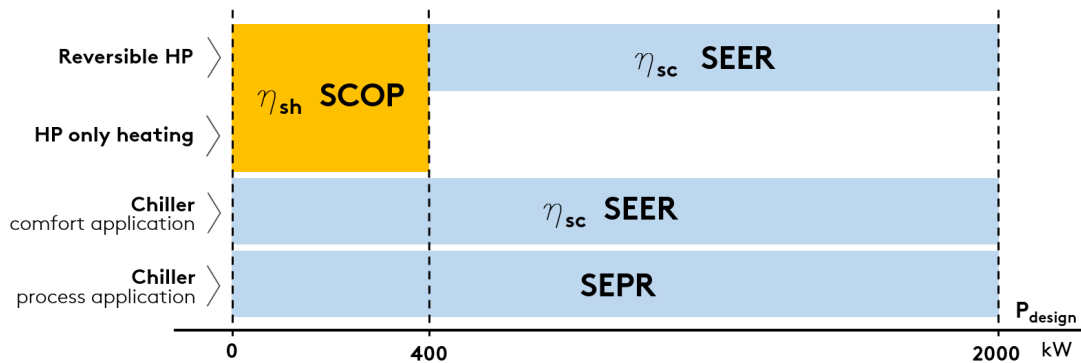

Some notes and clarifications:

For comfort applications, regulation 2016/2281 sets the η_{sc} (SEER) ratio in two different operating conditions:

- SEER calculated with machine inlet/outlet water temperature of 12/7°C (low temperature application),
- SEER calculated with machine inlet/outlet water temperature of 23/18°C (medium temperature application).

The minimum efficiency requirement is the same, but can be met at condition 12/7°C or at condition 23/18°C, depending on the application envisaged for the machine.

Regulation 2013/813 distinguishes two different types: at low temperature and at medium temperature.

The following refer to the application at low temperature: (low temperature application) all heat pumps whose maximum delivery temperature for heating purposes is lower than 52°C with source at temperature of -7°C and -8°C wet bulb (air-water unit) or inlet 10°C (water-water unit), at the reference design conditions for an average climate. For these, the efficiency ratio is "low temperature application" (outlet water temperature 35°C).

For all the other heat pumps, the efficiency ratio is related to "medium temperature application" (outlet water temperature 55°C).

The ratios must be calculated according to the reference European heating season in average climatic conditions.

The minimum efficiency requirements set by the regulations are indicated below.

REGULATION 2016/2281, comfort application

TYPE OF UNIT		MINIMUM REQUIREMENT			
		Tier 1		Tier 2 (2021)	
SOURCE	P _{design}	η_{sc} [%]	SEER	η_{sc} [%]	SEER
air	< 400kW	149	3,8	161	4,1
air	\geq 400kW	161	4,1	179	4,55
water	< 400kW	196	5,1	200	5,2
water	\geq 400kW and < 1500kW	227	5,875	252	6,5
water	\geq 1500kW	245	6,325	272	7

REGULATION 2016/2281, process application

TYPE OF UNIT		MINIMUM REQUIREMENT	
		Tier 1	Tier 2 (2021)
SOURCE	P _{design}	SEPR	SEPR
air	< 400kW	4,5	5
air	\geq 400kW	5	5,5
water	< 400kW	6,5	7
water	\geq 400kW and < 1500kW	7,5	8
water	\geq 1500kW	8	8,5

REGULATION 2013/813

SOURCE	APPLICATION	MINIMUM REQUIREMENT	
		η_{sh} [%]	SCOP
air	low temperature application	125	3,2
water	low temperature application	125	3,325
air	medium temperature application	110	2,825
water	medium temperature application	110	2,95

The conformity of the product must be checked according to the type of application, whether comfort or process, and at the required outlet water temperature.

The two schematic tables below, respectively for comfort application and for process application, indicate the reference of the required conformity according to the type of product and the set point temperature (reference to regulations 2016/2281 and 2013/813).

Important note: for mixed comfort and process applications, the reference application for conformity is the comfort application.

COMFORT APPLICATION

PRODUCT	OUTLET WATER TEMPERATURE	COMPLIANCE INDEX	REGULATION
Chiller	< 18°C	SEER/η _{sc} low temperature application	2016/2281
	≥ 18°C	SEER/η _{sc} medium temperature application	2016/2281
Heat pumps (reversible and only heating) P_{design} ≤ 400kW		SCOP/η _{sh}	2013/813
Reversible heat pumps P_{design} > 400kW	< 18°C	SEER/η _{sc} low temperature application	2016/2281
	≥ 18°C	SEER/η _{sc} medium temperature application	2016/2281
Heat pumps only heating P_{design} > 400kW		-	-

- = exemption from Ecodesign

PROCESS APPLICATION

PRODUCT	OUTLET WATER TEMPERATURE	COMPLIANCE INDEX	REGULATION
Chiller	≥ +2°C , ≤ 12°C	SEPR	2016/2281
	> 12°C	-	-
	> -8°C , < +2°C	-	-

- = exemption from Ecodesign

Some specifications and notes follow.

Partly completed machinery

The term partly completed machinery refers to all units without a user-side or source-side heat exchanger, and therefore to all LC, LE, LC/HP and LE/HP versions. Since these are "non-complete" machines, conformity with Ecodesign depends on combination with the remote heat exchanger.

All the partly completed machinery is CE marked and accompanied by a declaration of conformity. Installation in European Union countries is therefore allowed; correct selection and installation of the remote heat exchanger must be ensured, in accordance with the above cases.

EC fans:

The only option that positively affects the performance of the unit, by increasing its seasonal energy efficiency ratio, is the VEC accessory.

A unit equipped with EC fans has a higher SEER (η_{sc}) than the configuration with standard fans.

RANGE OMEGA SKY Xi LGW

The Ecodesign/ErP Directive (2009/125/EC) lays down new standards for more efficient energy use.

Several regulations are part of the directive, and set mandatory seasonal efficiency targets for sale in the European Union.

The unit therefore, to be CE marked and sold in the EU market, must comply with the minimum requirements imposed by the regulations in question.

Regarding the Omega Sky Xi LGW range, the reference regulations in the various configurations are:

- Regulation 2016/2281, for chillers and heat pumps with $P_{design} > 400$ kW

Minimum efficiency requirements are imposed through seasonal energy efficiency indices, respectively:

- η_{sc} (SEER) for comfort applications
- SEPR for process applications.

As regards the 2016/2281 regulation starting from 1 January 2021, the minimum required efficiency limit will be raised (Tier 2) compared to the current standard (Tier 1).

With reference to the Omega Sky Xi LGW range, below is a list of concerned regulations relating to the different units in their various configurations:

Omega Sky Xi LGW:

- regulation 2016/2281

Omega Sky Xi LGW OH:

- Regulation 2013/813, from size 19.1 to 39.1
- As these are heat pumps for heating applications only with $P_{design} > 400$ kW, sizes from 45.1 onwards are exempt from conformity requirements; All OH units are CE marked.

Omega Sky Xi LGW HPW:

- Regulation 2016/2281, from size 45.1 to 73.1
- Regulation 2013/813, from size 19.1 to 39.1

The tables below give information on the conformity of the units and the seasonal energy performance ratios with regard to the reference regulation.

OMEGA SKY Xi LGW

			19.1	21.1	26.1	30.1	36.1	39.1	45.1	54.1	61.1	73.1
REGULATION 2016/2281												
Pdesign	(1)	kW	184	221	264	295	337	383	431	524	592	684
COMFORT												
η_{sc}	(1)	%	280%	294%	302%	307%	316%	317%	318%	319%	317%	291%
SEER	(1)		7,21	7,56	7,75	7,88	8,1	8,12	8,15	8,18	8,12	7,48
Compliance Tier 1	(1)		Y	Y	Y	Y	Y	Y	Y	Y	Y	Y
Compliance Tier 2 (2021)	(1)		Y	Y	Y	Y	Y	Y	Y	Y	Y	Y
PROCESS												
SEPR	(3)		8,14	8,46	8,51	8,56	8,67	8,8	8,85	8,95	8,94	7,89
Compliance Tier 1	(3)		Y	Y	Y	Y	Y	Y	Y	Y	Y	Y
Compliance Tier 2 (2021)	(3)		Y	Y	Y	Y	Y	Y	Y	Y	Y	Y

Y = unit in compliance with Ecodesign at the indicated condition.

N = unit not in compliance with Ecodesign at the given condition: it can be installed only in non-EU countries.

(1) User-side heat exchanger water inlet/outlet temperature 12/7°C (low temperature application), with reference to regulation 2016/2281 and standard EN 14825.

(3) User-side heat exchanger water inlet/outlet temperature 12/7°C, with reference to regulation 2016/2281 and norm EN 14825.

OMEGA SKY Xi LGW HPW

			45.1	54.1	61.1	73.1
REGULATION 2016/2281						
Pdesign	(1)	kW	431	524	592	684
COMFORT						
η_{sc}	(1)	%	318%	319%	317%	291%
SEER	(1)		8,15	8,18	8,12	7,48
Compliance Tier 1	(1)		Y	Y	Y	Y
Compliance Tier 2 (2021)	(1)		Y	Y	Y	Y
PROCESS						
SEPR	(3)		8,85	8,95	8,94	7,89
Compliance Tier 1	(3)		Y	Y	Y	Y
Compliance Tier 2 (2021)	(3)		Y	Y	Y	Y

Y = unit in compliance with Ecodesign at the indicated condition.

N = unit not in compliance with Ecodesign at the given condition: it can be installed only in non-EU countries.

(1) User-side heat exchanger water inlet/outlet temperature 12/7°C (low temperature application), with reference to regulation 2016/2281 and standard EN 14825.

(3) User-side heat exchanger water inlet/outlet temperature 12/7°C, with reference to regulation 2016/2281 and norm EN 14825.

OMEGA SKY Xi LGW HPW

			19.1	21.1	26.1	30.1	36.1	39.1
REGULATION 2013/813								
Pdesign	(1)	kW	201	239	285	318	363	386
η_{sh}	(1)	%	164%	170%	172%	174%	177%	179%
SCOP	(1)		4,3	4,45	4,48	4,55	4,62	4,66
Compliance	(1)		Y	Y	Y	Y	Y	Y

Y = unit in compliance with Ecodesign at the indicated condition.

N = unit not in compliance with Ecodesign at the given condition: it can be installed only in non-EU countries.

(1) User-side heat exchanger water inlet/outlet temperature 47/55°C (SCOP MT), Average climate profile, with reference to regulation 2013/813 and norm EN 14825.

OMEGA SKY Xi LGW OH

			19.1	21.1	26.1	30.1	36.1	39.1
REGULATION 2013/813								
Pdesign	(1)	kW	201	239	285	318	363	386
η_{sh}	(1)	%	164%	170%	172%	174%	177%	179%
SCOP	(1)		4,3	4,45	4,48	4,55	4,62	4,66
Compliance	(1)		Y	Y	Y	Y	Y	Y

Y = unit in compliance with Ecodesign at the indicated condition.

N = unit not in compliance with Ecodesign at the given condition: it can be installed only in non-EU countries.

(1) User-side heat exchanger water inlet/outlet temperature 47/55°C (SCOP MT), Average climate profile, with reference to regulation 2013/813 and norm EN 14825.

ELECTRICAL SPECIFICATIONS

OMEGA SKY Xi LGW

			19.1	21.1	26.1	30.1	36.1
General electrical specifications							
Max. absorbed power (FLI)	(1)	kW	45	55	75	75	90
Max. absorbed current (FLA)	(1)	A	88	106	145	145	169
Rated current (Inom)	(2)	A	56	64	76	85	96
cosφ standard unit	(2)		0,97	0,97	0,97	0,97	0,97
Max. inrush current (MIC)	(3)	A	< 10	< 10	< 10	< 10	< 10
Power supply		V/ph/Hz	400V / 3ph / 50Hz				
Power supply for auxiliary circuits		V/ph/Hz	230V-24V / 1ph / 50Hz				
Suggested line section	(4)	mm ²	3x35+1G27	3x50+1G27	3x50+1G27	3x50+1G27	3x120+1G72
Suggested line protection	(5)		NH00gG 100A	NH00gG 125A	NH00gG 160A	NH00gG 160A	NH1gG 250A

- (1) Data regarding the unit without accessories working in maximum power absorption conditions
- (2) Data referring to the unit without options and operating in standard conditions: source-side heat exchanger input/output water temperature 30/35°C; user-side heat exchanger input/output water temperature 12/7°C.
- (3) Max. effective RMS current value when the last compressor gets started (FLA of entire unit - FLA of largest compressor + LRA of largest compressor)
- (4) These values are calculated for cables with operating temperature of 40°C, EPR insulation and a line with a maximum length of 50m. The line section must be determined by a qualified technician based on the protection devices, the length of the line, the type of cable used and the type of installation.
- (5) The correct system for line protection must be determined by a qualified technician based on the length of the line, the type of cable used and the type of installation.

OMEGA SKY Xi LGW

			39.1	45.1	54.1	61.1	73.1
General electrical specifications							
Max. absorbed power (FLI)	(1)	kW	90	110	132	160	160
Max. absorbed current (FLA)	(1)	A	169	206	246	293	293
Rated current (Inom)	(2)	A	109	122	145	163	199
cosφ standard unit	(2)		0,97	0,97	0,97	0,97	0,97
Max. inrush current (MIC)	(3)	A	< 10	< 10	< 10	< 10	< 10
Power supply		V/ph/Hz	400V / 3ph / 50Hz				
Power supply for auxiliary circuits		V/ph/Hz	230V-24V / 1ph / 50Hz				
Suggested line section	(4)	mm ²	3x120+1G72	3x185+1G95	3x185+1G95	3x240+1G120	3x240+1G120
Suggested line protection	(5)		NH1gG 250A	NH2gG 315A	NH2gG 315A	NH2gG 400A	NH2gG 400A

- (1) Data regarding the unit without accessories working in maximum power absorption conditions
- (2) Data referring to the unit without options and operating in standard conditions: source-side heat exchanger input/output water temperature 30/35°C; user-side heat exchanger input/output water temperature 12/7°C.
- (3) Max. effective RMS current value when the last compressor gets started (FLA of entire unit - FLA of largest compressor + LRA of largest compressor)
- (4) These values are calculated for cables with operating temperature of 40°C, EPR insulation and a line with a maximum length of 50m. The line section must be determined by a qualified technician based on the protection devices, the length of the line, the type of cable used and the type of installation.
- (5) The correct system for line protection must be determined by a qualified technician based on the length of the line, the type of cable used and the type of installation.

OMEGA SKY Xi LGW - HPW & OH

			19.1	21.1	26.1	30.1	36.1
General electrical specifications							
Max. absorbed power (FLI)	(1)	kW	75	90	90	110	132
Max. absorbed current (FLA)	(1)	A	145	169	169	206	246
Rated current (Inom)	(2)	A	69	79	94	104	119
cosφ standard unit	(2)		0,97	0,97	0,97	0,97	0,97
Max. inrush current (MIC)	(3)	A	< 10	< 10	< 10	< 10	< 10
Power supply		V/ph/Hz	400V / 3ph / 50Hz				
Power supply for auxiliary circuits		V/ph/Hz	230V-24V / 1ph / 50Hz				
Suggested line section	(4)	mm ²	3x50+1G27	3x185+1G95	3x120+1G72	3x185+1G95	3x185+1G95
Suggested line protection	(5)		NH00gG 160A	NH1gG 250A	NH1gG 250A	NH2gG 315A	NH2gG 315A

- (1) Data regarding the unit without accessories working in maximum power absorption conditions
- (2) Data referring to the unit without options and operating in standard conditions: source-side heat exchanger input/output water temperature 30/35°C; user-side heat exchanger input/output water temperature 12/7°C.
- (3) Max. effective RMS current value when the last compressor gets started (FLA of entire unit - FLA of largest compressor + LRA of largest compressor)
- (4) These values are calculated for cables with operating temperature of 40°C, EPR insulation and a line with a maximum length of 50m. The line section must be determined by a qualified technician based on the protection devices, the length of the line, the type of cable used and the type of installation.
- (5) The correct system for line protection must be determined by a qualified technician based on the length of the line, the type of cable used and the type of installation.

OMEGA SKY Xi LGW - HPW & OH

			39.1	45.1	54.1	61.1	73.1
General electrical specifications							
Max. absorbed power (FLI)	(1)	kW	132	160	200	200	250
Max. absorbed current (FLA)	(1)	A	246	293	363	363	430
Rated current (Inom)	(2)	A	133	149	178	200	243
cosφ standard unit	(2)		0,97	0,97	0,97	0,97	0,97
Max. inrush current (MIC)	(3)	A	< 10	< 10	< 10	< 10	< 10
Power supply		V/ph/Hz	400V / 3ph / 50Hz				
Power supply for auxiliary circuits		V/ph/Hz	230V-24V / 1ph / 50Hz				
Suggested line section	(4)	mm ²	3x185+1G95	3x240+1G120	2x(3x150+1G95)	2x(3x150+1G95)	2x(3x185+1G95)
Suggested line protection	(5)		NH2gG 315A	NH2gG 400A	NH3gG 500A	NH3gG 500A	NH3gG 630A

- (1) Data regarding the unit without accessories working in maximum power absorption conditions
- (2) Data referring to the unit without options and operating in standard conditions: source-side heat exchanger input/output water temperature 30/35°C; user-side heat exchanger input/output water temperature 12/7°C.
- (3) Max. effective RMS current value when the last compressor gets started (FLA of entire unit - FLA of largest compressor + LRA of largest compressor)
- (4) These values are calculated for cables with operating temperature of 40°C, EPR insulation and a line with a maximum length of 50m. The line section must be determined by a qualified technician based on the protection devices, the length of the line, the type of cable used and the type of installation.
- (5) The correct system for line protection must be determined by a qualified technician based on the length of the line, the type of cable used and the type of installation.

FLOW RATE RANGES OF HEAT EXCHANGERS

The units are sized and optimized for the following nominal conditions:

inlet-outlet of the source-side heat exchanger 30/35°C

inlet-outlet of the user-side heat exchanger 12/7°C

The units can work at design conditions different from nominal conditions, provided that:

the design condition falls within the operating limits specified below

the unit is equipped with all the accessories necessary for operation of the unit (e.g. brine kit, condensation control)

the flow rate at design conditions (that is, of the specific application) must always come within the allowed flow rate ranges specified below. If the design conditions require a water flow rate that does not come within the allowed operating range, you must contact our sales department that will identify the most suitable solution for the specific application.

OMEGA SKY Xi LGW

	Evaporator		Condenser	
	Qmin	Qmax	Qmin	Qmax
	m ³ /h	m ³ /h	m ³ /h	m ³ /h
19.1	25	48	30	57
21.1	30	57	35	68
26.1	30	68	45	81
30.1	40	76	50	91
36.1	45	87	55	104
39.1	50	99	65	118
45.1	55	111	75	132
54.1	65	135	80	161
61.1	70	153	95	181
73.1	90	176	115	211

OMEGA SKY Xi LGW HPW

	Evaporator		Condenser	
	Qmin	Qmax	Qmin	Qmax
	m ³ /h	m ³ /h	m ³ /h	m ³ /h
19.1	25	48	30	57
21.1	30	57	35	68
26.1	30	68	45	81
30.1	40	76	50	91
36.1	45	87	55	104
39.1	50	99	65	118
45.1	55	111	75	132
54.1	65	135	80	161
61.1	70	153	95	181
73.1	90	176	115	211

OMEGA SKY Xi LGW OH

	Evaporator		Condenser	
	Qmin	Qmax	Qmin	Qmax
	m ³ /h	m ³ /h	m ³ /h	m ³ /h
19.1	25	48	30	57
21.1	30	57	35	68
26.1	30	68	45	81
30.1	40	76	50	91
36.1	45	87	55	104
39.1	50	99	65	118
45.1	55	111	75	132
54.1	65	135	80	161
61.1	70	153	95	181
73.1	90	176	115	211

OPERATING LIMITS

Omega Sky Xi LGW - Omega Sky Xi LGW OH - Omega Sky Xi LGW HPW

COOLING

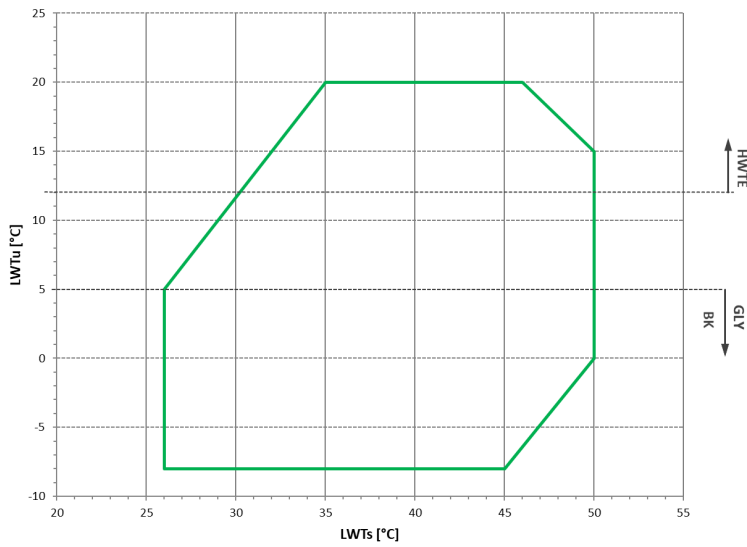

HEATING

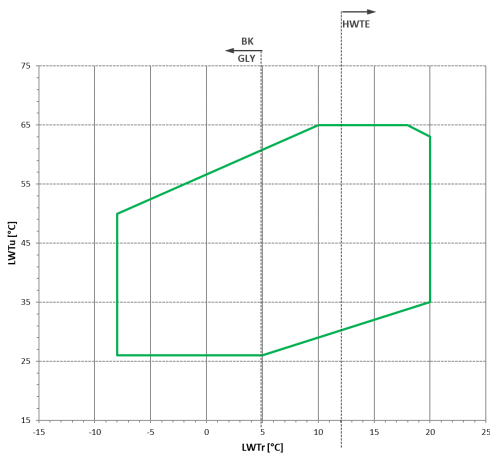

TOTAL RECOVERY

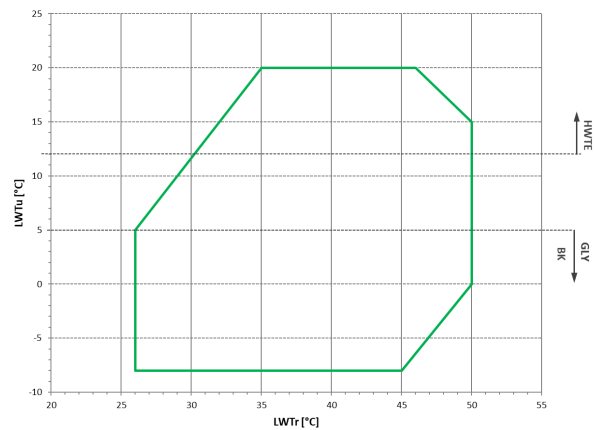

- LWTs:** water outlet temperature from the source-side heat exchanger
- LWTu:** water outlet temperature from the user-side heat exchanger
- LWTr:** water outlet temperature from the recovery exchanger
- BK:** For LWTu below +5°C, it is mandatory to fit the "Brine Kit LGW" accessory
- HWTE:** For evaporator leaving water temperature higher than 12°C, accessory "HWTE" is mandatory

For LWTu below +5°C, it is compulsory to use suitable percentages of antifreeze additives (glycols) to prevent ice formation in the exchanger.

The inlet and outlet temperatures of the user-side exchanger must be given on ordering to allow correct setting of the alarm parameters and verification of the sizing of the expansion valve.

The cooling set point can then be changed by the customer in an interval that, compared to the set point given on ordering, ranges from -1K up to the maximum temperature allowed by the above-stated operating limits.

The unit will be optimized to work at the set point temperatures given on ordering. For different set points, the cooling capacity provided and the level of efficiency of the machine could decrease and move away from these conditions.

NOISE LEVELS

OMEGA SKY Xi LGW

	Octave bands [dB]																Total [dB(A)]	
	63 Hz		125 Hz		250 Hz		500 Hz		1000 Hz		2000 Hz		4000 Hz		8000 Hz		Lw_tot	Lp_tot
	Lw	Lp	Lw	Lp	Lw	Lp	Lw	Lp	Lw	Lp	Lw	Lp	Lw	Lp	Lw	Lp		
19.1	100	82	94	76	92	73	98	79	96	78	91	72	80	61	73	55	99	81
21.1	100	82	94	76	92	73	98	79	96	78	91	72	80	61	73	55	99	81
26.1	101	83	95	77	93	74	99	80	97	79	92	73	81	62	74	56	100	82
30.1	101	83	95	77	93	74	99	80	97	79	92	73	81	62	74	56	100	82
36.1	102	84	96	78	94	75	100	81	98	80	92	74	82	63	75	57	101	83
39.1	102	83	96	77	94	75	100	81	98	79	93	73	82	63	75	56	101	82
45.1	103	84	97	78	95	76	101	82	99	80	94	75	83	64	76	57	102	83
54.1	103	84	97	78	95	76	101	82	99	80	94	75	83	64	76	57	102	83
61.1	105	86	99	80	97	78	103	84	101	82	95	76	85	66	78	59	104	85
73.1	107	88	101	82	99	79	105	85	103	84	97	78	87	67	80	61	106	87

OMEGA SKY Xi /LN

	Octave bands [dB]																Total [dB(A)]	
	63 Hz		125 Hz		250 Hz		500 Hz		1000 Hz		2000 Hz		4000 Hz		8000 Hz		Lw_tot	Lp_tot
	Lw	Lp	Lw	Lp	Lw	Lp	Lw	Lp	Lw	Lp	Lw	Lp	Lw	Lp	Lw	Lp		
19.1	100	81	96	77	92	73	93	74	90	71	86	68	77	59	72	54	94	76
21.1	100	81	96	77	92	73	93	74	90	71	86	68	77	59	72	54	94	76
26.1	101	82	97	78	93	74	94	75	91	72	87	69	78	60	73	55	95	77
30.1	101	82	97	78	93	74	94	75	91	72	87	69	78	60	73	55	95	77
36.1	102	83	98	79	94	75	95	76	92	73	88	70	79	61	74	56	96	78
39.1	102	83	98	79	94	75	95	76	92	73	88	69	79	60	74	55	96	77
45.1	103	84	99	80	95	76	96	77	93	74	89	70	80	61	75	56	97	78
54.1	103	84	99	80	95	76	96	77	93	74	89	70	80	61	75	56	97	78
61.1	105	86	101	82	97	78	98	79	95	76	91	72	82	63	77	58	99	80
73.1	107	87	103	83	99	79	100	80	97	77	93	74	84	65	79	60	101	82

Reference conditions: source-side heat exchanger input/output water temperature 30/35°C; user-side heat exchanger input/output water temperature 12/7°C; unit operating at rated capacity, without any option.

Lw: sound power levels.

Values obtained from measures taken according to standard ISO 3744.

Lw_tot is the only binding value.

Lp: sound pressure levels calculated from sound power levels, related to distance of 1 m from the unit in free field with directivity factor Q=2. Non-binding values.

The acoustic data are related to standard conditions in referable and reproducible operating conditions. All data with the exception of Lw_tot are provided for illustrative purposes only and can not be used for forecasting purposes or for the verification of binding limits.

With special reference to noise emissions, the Manufacturer takes liability for their conformity, limited to the declared Lw_tot value.

Any and all other Manufacturer's liability for the impact of such emissions in relation to the location of the machine and other conditions related to machine installation is excluded. The environment and the installation conditions, as well as the operating modes, can alter the sound emissions. Any assessment concerning these conditions falls within the area of competence of the plant designer and/or the fitter.

DIMENSIONAL DIAGRAMS

OMEGA SKY XI LGW - XI LGW OH - XI LGW HPW

DDIM000472

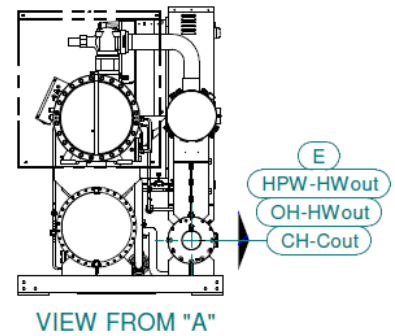
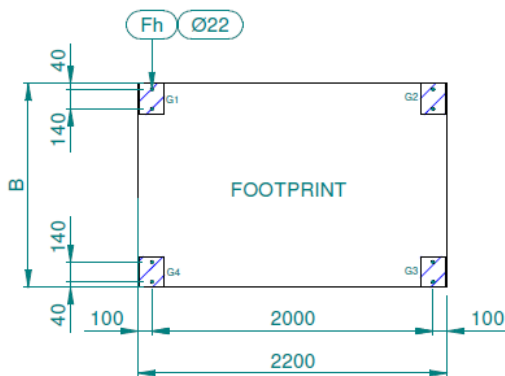
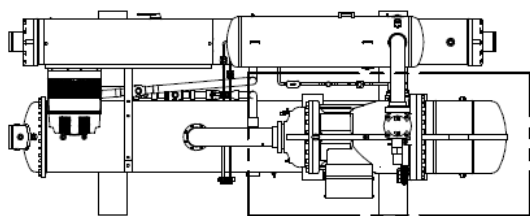
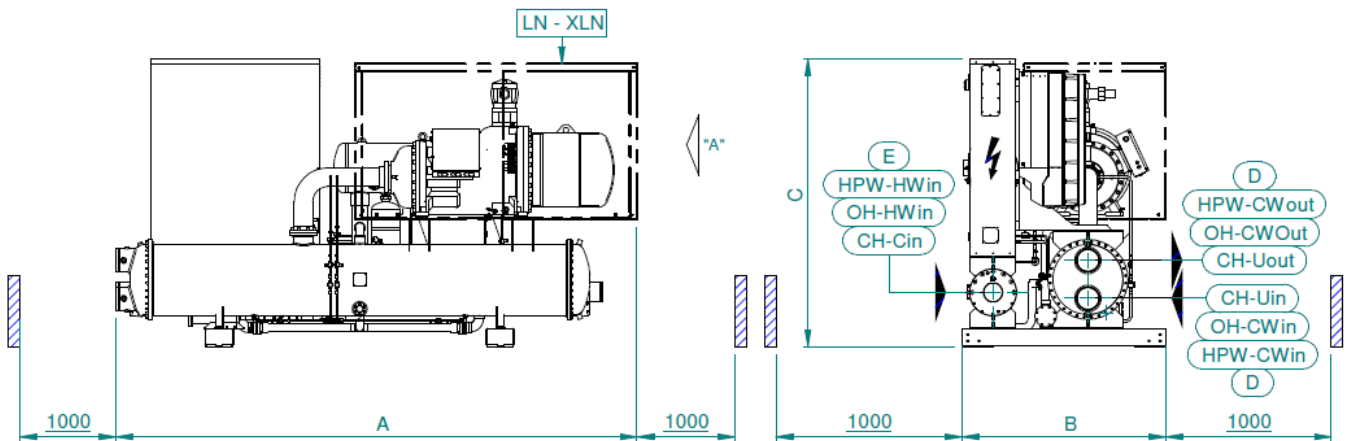

Note: These drawings are not contractually binding. For the installation design, refer to the specific dimensional drawing available on request.
The weights could change in case of options.

Size	Size LGW	Dimensions			Connections	
		A	B	C	D	E
25.1	19.1	3700	1500	2050	OD 114.3	OD 114.3
29.1	21.1	3700	1500	2050	OD 114.3	OD 114.3
35.1	26.1	3800	1550	2100	OD 139.7	OD 139.7
40.1	30.1	3800	1550	2100	OD 139.7	OD 139.7
47.1	36.1	3800	1550	2100	OD 139.7	OD 139.7
53.1	39.1	3900	1550	2150	OD 168.3	OD 139.7
60.1	45.1	3900	1550	2150	OD 168.3	OD 139.7
72.1	54.1	4100	1670	2300	OD 168.3	OD 139.7
81.1	61.1	4150	1670	2400	OD 219.1	OD 139.7
97.1	73.1	4250	1850	2400	OD 219.1	OD 139.7

Model	Model LGW	Weight	Operating Weight
25.1	19.1	1924	2025
25.1 LN-XLN	19.1 LN	2114	2215
29.1	21.1	2033	2145
29.1 LN-XLN	21.1 LN	2223	2335
34.1	26.1	2356	2504
34.1 LN-XLN	26.1 LN	2546	2694
40.1	30.1	2436	2602
40.1 LN-XLN	30.1 LN	2666	2832
47.1	36.1	2567	2757
47.1 LN-XLN	36.1 LN	2797	2987
53.1	39.1	2926	3151
53.1 LN-XLN	39.1 LN	3156	3381
60.1	45.1	3036	3279
60.1 LN-XLN	45.1 LN	3266	3509
72.1	54.1	3635	3960
72.1 LN-XLN	54.1 LN	3935	4260
81.1	61.1	4086	4442
81.1 LN-XLN	61.1 LN	4386	4742
97.1	73.1	4744	5160
97.1 LN-XLN	73.1 LN	5044	5460

Note: These drawings are not contractually binding. For the installation design, refer to the specific dimensional drawing available on request.

INSTALLATION ADVICE

The units described in this document are, by nature, strongly affected by the characteristics of the system, the working conditions and the installation site.

Remember that the unit must be installed by a qualified and skilled technician, and in compliance with the national legislation in force in the destination country.

The installation must be done in such a way that it will be possible to carry out all routine and non-routine maintenance operations.

Before starting any work, you must carefully read the "Installation, operation and maintenance manual" of the machine and do the necessary safety checks to prevent any malfunctioning or hazards.

We give some advice below that will allow you to increase the efficiency and reliability of the unit and therefore of the system into which it is inserted.

Water characteristics

To preserve the life of the exchangers, the water is required to comply with some quality parameters and it is therefore necessary to make sure its values fall within the ranges indicated in the following table:

Total hardness	2,0 ÷ 6,0 °f
Langelier index	- 0,4 ÷ 0,4
pH	7,5 ÷ 8,5
Electrical conductivity	10 ÷ 500 µS/cm
Organic elements	-
Hydrogen carbonate (HCO₃⁻)	70 ÷ 300 ppm
Sulphates (SO₄²⁻)	< 50 ppm
Hydrogen carbonate / Sulphates (HCO₃⁻/SO₄²⁻)	> 1
Chlorides (Cl⁻)	< 50 ppm
Nitrates (NO₃⁻)	< 50 ppm
Hydrogen sulphide (H₂S)	< 0,05 ppm
Ammonia (NH₃)	< 0,05 ppm
Sulphites (SO₃), free chlorine (Cl₂)	< 1 ppm
Carbon dioxide (CO₂)	< 5 ppm
Metal cations	< 0,2 ppm
Manganese ions (Mn⁺⁺)	< 0,2 ppm
Iron ions (Fe²⁺ , Fe³⁺)	< 0,2 ppm
Iron + Manganese	< 0,4 ppm
Phosphates (PO₄³⁻)	< 2 ppm
Oxygen	< 0,1 ppm

Installation of water filters on all the hydraulic circuits is obligatory.

The supply of the most suitable filters for the unit can be requested as accessory. In this case, the filters are supplied loose and must be installed by the customer following the instructions given in the installation, operation and maintenance manual.

Glycol mixtures

With temperatures below 5°C, it is mandatory to work with water and anti-freeze mixtures, and also change the safety devices (anti-freeze, etc.), which must be carried out by qualified authorised personnel or by the manufacturer.

Liquid outlet temperature or minimum ambient temperature	°C	0	-5	-10	-15	-20	-25	-30	-35	-40
Freezing point	°C	-5	-10	-15	-20	-25	-30	-35	-40	-45
Ethylene glycol	%	6	22	30	36	41	46	50	53	56
Propylene glycol	%	15	25	33	39	44	48	51	54	57

The quantity of antifreeze should be considered as % on weight

Minimum water content in the system

For correct operation of the unit, it is necessary to ensure a buffering on the system such as to comply with the minimum operating time considering the greater between the minimum OFF time and the minimum ON time. In short, these contribute to limiting the number of times the compressors are switched on per hour and to preventing undesired deviations from the set point of the delivered water temperature.

Larger amounts of water are in any case always preferable, because they allow a smaller number of starts and switch-offs of the compressors, less wear of them and an increase in the efficiency of the system as a consequence of a reduction in the number of transients.

$$V_{min} = \frac{P_{tot} \cdot 1.000}{N} \cdot \frac{300}{\Delta T \cdot \rho \cdot c_p} + P_{tot} \cdot 0,8$$

where

V_{min} is the minimum water content of the system [l]

P_{tot} is the total cooling capacity of the machine [kW]

N: number of capacity reduction steps

ΔT : differential allowed on the water temperature. Unless otherwise specified, this value is considered to be 2.5K

ρ : density of the heat-carrying fluid. Unless otherwise specified, the density of water is considered

c_p : specific heat of the heat-carrying fluid. Unless otherwise specified, the specific heat of water is considered

Considering the use of water and grouping together some terms, the formula can be re-written as follows:

$$V_{min} = \frac{P_{tot}}{N} \cdot 28,66 + P_{tot} \cdot 0,8$$

For the N values, consider the following convention:

- for units with 1 compressor N = 4

Installation site

To determine the best installation site for the unit and its orientation, you should pay attention to the following points:

- compliance with the clearance spaces indicated in the official dimensional drawing of the unit must be guaranteed so as to ensure accessibility for routine and non-routine maintenance operations
- you should consider the origin of the hydraulic pipes and their diameters because these affect the radiuses of curvature and therefore the spaces needed for installing them
- you should consider the position of the cable inlet on the electrical control panel of the unit as regards the origin of the power supply
- if the installation includes several units side by side, you should consider the position and dimensions of the manifolds of the heat exchangers

Once the best position for the unit has been identified, you must check that the support slab has the following characteristics:

- its dimensions must be proportionate to those of the unit: if possible, longer and wider than the unit by at least 30 cm and 15/20cm higher than the surrounding surface
- it must be able to bear at least 4 times the operating weight of the unit
- must allow the unit to be installed in a level position

The units are designed and built to reduce to a minimum the level of vibration transmitted to the ground, but it is in any case advisable to use rubber or spring anti-vibration mounts, which are available as accessory and should be requested when ordering.

The anti-vibration mounts must be fixed to the machine before positioning the unit on the ground.

